

DO NOT SCALE FROM THIS PRINT

DESIGNED & DIMENSIONED IN MILLIMETERS [INCHES]

MCX7-P-C-XX-ST-CA3

GENDER  
-P: PLUG

TERMINATION  
-CA3: CABLE (RG179)

TYPE  
-C: CABLE

ORIENTATION  
-ST: STRAIGHT

PLATING SPECIFICATION

-HN: 30μ" GOLD CENTER CONTACT, 100μ" NICKEL OUTER CONTACT  
-H: 30μ" GOLD CENTER CONTACT, 3μ" GOLD OUTER CONTACT (SEE TABLE 1)

TABLE 1			
ITEM	COMPONENT	-HN	-H
1	SUB ASSEMBLY	SUB-MCX7-P-C-FN-ST-CA3	SUB-MCX7-P-C-F-ST-CA3
2	PIN	MCX7-P-C-H-ST-CA3-PIN	
3	OUTER FERRULE	MCX-FER-001-N	MCX-FER-001-F

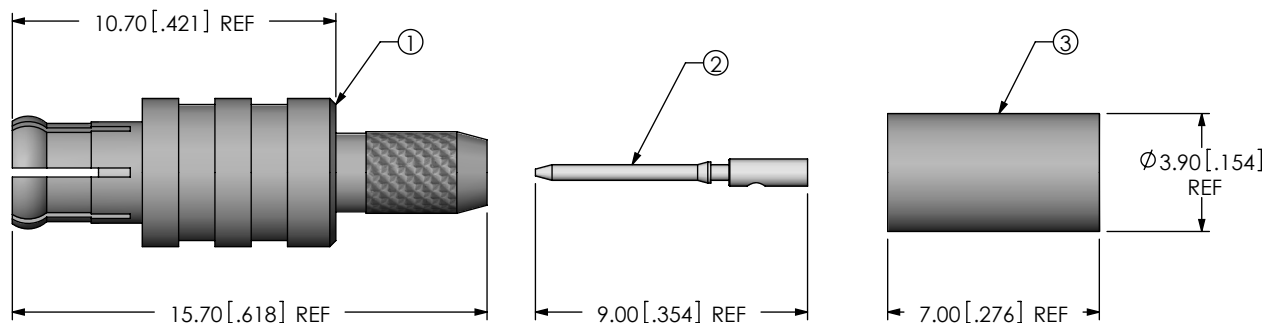

NOTES:

1. NOTE DELETED.
2. NOTE DELETED.
3. NOTE DELETED.
4. NOTE DELETED.
5. PRODUCT TO BE BULK PACKAGED PER PACKAGING STANDARD CO-RF-WI-3040-M.
6. NOTE DELETED.
7. NOTE DELETED.
8. NOTE DELETED.

F:\DWG\MISC\MKTG\MCX7-P-C-XX-ST-CA3-MKT.SLDDRW

<p>UNLESS OTHERWISE SPECIFIED, DIMENSIONS ARE IN MILLIMETERS [INCHES]. TOLERANCES ARE:</p> <p>DECIMALS      ANGLES</p> <p>.X: ±0.3 [.01]      5°</p> <p>.XX: ±0.13 [.005]</p> <p>.XXX: ±0.051 [.0020]</p>	<p><b>PROPRIETARY NOTE</b></p> <p>THIS DOCUMENT CONTAINS CONFIDENTIAL AND PROPRIETARY INFORMATION AND ALL DESIGN, MANUFACTURING, REPRODUCTION, USE, PATENT RIGHTS AND SALES RIGHTS ARE EXPRESSLY RESERVED BY SAMTEC, INC. THIS DOCUMENT SHALL NOT BE DISCLOSED, IN WHOLE OR PART, TO ANY UNAUTHORIZED PERSON OR ENTITY NOR REPRODUCED, TRANSFERRED OR INCORPORATED IN ANY OTHER PROJECT IN ANY MANNER WITHOUT THE EXPRESS WRITTEN CONSENT OF SAMTEC, INC.</p>	 <p>520 PARK EAST BLVD, NEW ALBANY, IN 47150 PHONE: 812-944-6733    FAX: 812-948-5047 e-Mail: info@SAMTEC.com    code 55322</p>
<p><b>MATERIAL:</b>      DO NOT SCALE DRAWING      SHEET SCALE: 4:1</p> <p>SHELL, FERRULES: BRASS CONTACT: BRASS DIELECTRIC: PTFE</p>	<p>DESCRIPTION: TRUE 75 OHM, MCX STRAIGHT PLUG, RG179</p> <p>DWG. NO. <b>MCX7-P-C-XX-ST-CA3</b></p> <p>BY: R MUSSER      02/06/2008      SHEET 1 OF 2</p>	

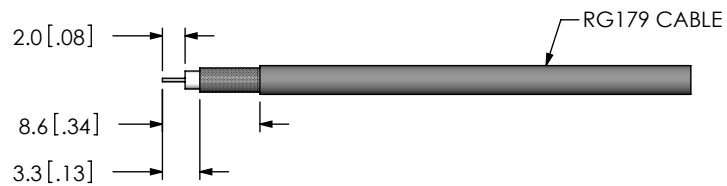

IN-PROCESS 1  
STRIP CABLE AND TIN INNER  
CONDUCTOR

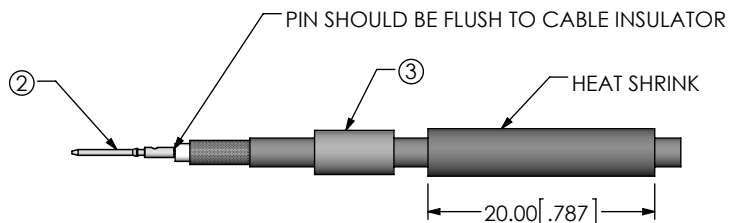

IN-PROCESS 2  
ADD HEAT SHRINK TUBING AND FERRULE,  
SOLDER SIGNAL PIN

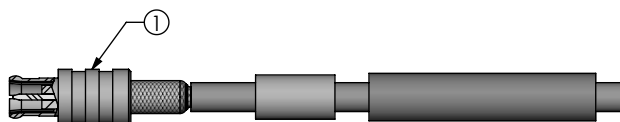

IN-PROCESS 3  
FLARE SHIELD & ADD SUB ASSEMBLY

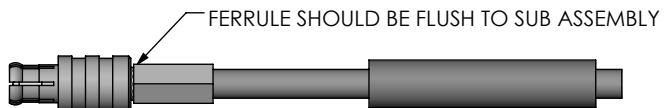

IN-PROCESS 4  
CRIMP FERRULE  
(USE RF CRIMP HAND TOOL #CAT-RF-FER-01,  
AND USE .128" HEX DIE)



IN-PROCESS 5  
ACTIVATE HEAT SHRINK

**PROPRIETARY NOTE**  
THIS DOCUMENT CONTAINS CONFIDENTIAL AND PROPRIETARY INFORMATION AND ALL DESIGN, MANUFACTURING, REPRODUCTION, USE, PATENT RIGHTS AND SALES RIGHTS ARE EXPRESSLY RESERVED BY SAMTEC, INC. THIS DOCUMENT SHALL NOT BE DISCLOSED, IN WHOLE OR PART, TO ANY UNAUTHORIZED PERSON OR ENTITY NOR REPRODUCED, TRANSFERRED OR INCORPORATED IN ANY OTHER PROJECT IN ANY MANNER WITHOUT THE EXPRESS WRITTEN CONSENT OF SAMTEC, INC.

DO NOT SCALE DRAWING

SHEET SCALE: 1.5:1



520 PARK EAST BLVD, NEW ALBANY, IN 47150  
PHONE: 812-944-6733 FAX: 812-948-5047  
e-Mail info@SAMTEC.com code 55322

DESCRIPTION:  
TRUE 75 OHM, MCX STRAIGHT PLUG, RG179

DWG. NO.  
MCX7-P-C-XX-ST-CA3

BY: R MUSSER 02/06/2008 SHEET 2 OF 2